



UMP

 bac

technika

ump



»»» CUSTOM PROJECTS

»»» ABOUT THE TECHNOLOGY



Tailored Solutions: We specialize in designing and manufacturing custom equipment to meet the unique needs of various industries. Our bespoke approach ensures that each piece of equipment aligns perfectly with our clients' operational goals.



Wide Range of Projects: Our portfolio includes a diverse array of custom machinery, such as sawdust bunkers, pallet dispensers, and conveyor systems, demonstrating our capability to address complex manufacturing challenges.



Industry Focus: We cater primarily to industries like recycling, furniture manufacturing, and logistics, where our custom solutions play a crucial role in enhancing operational efficiency. In recycling, our equipment helps optimize the handling and processing of materials, reducing waste and improving sustainability.

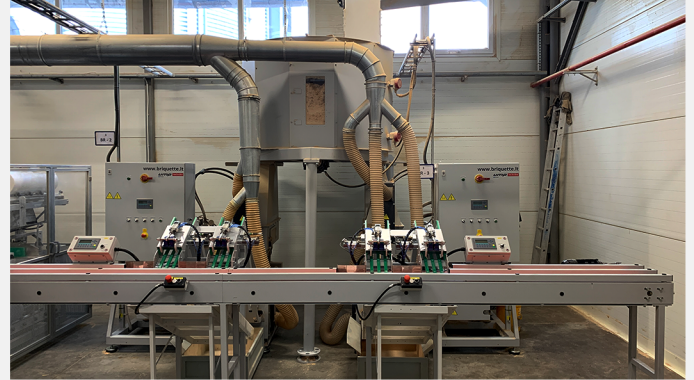

Innovation and Functionality: Innovation is at the heart of our custom projects, driving us to develop solutions that meet specific operational requirements. We prioritize efficiency, ensuring that our machinery is designed to optimize workflows and reduce downtime. Reliability is also key to consistent performance over time.

Nature  **Business**

Eco-Friendly Solution & Wallet-Wise Choice

»»» CUSTOM PRODUCTS



Sawdust bunker UB-180: sawdust bunker and filling hopper houses up to 2.8m³ of sawdust and supplies it to a single, or twin BP500A briquette press systems to ensure their maximum efficiency. Our system uses a 0.9kW electric engine which is both efficient and reliable. The bunker is designed to be placed on top of existing briquette presses to save up valuable floor space..

Pallet Dispense PD-10: The Automated Pallet Dispenser PD-10 serves as the cornerstone of your automation processes, significantly enhancing efficiency and ergonomics in the workplace. Designed to accommodate up to 10 euro pallets of standard dimensions (1200×800 or 1200×1200 mm), this innovative unit eliminates the need for manual pallet preparation, thereby conserving time and minimizing physical strain on employees.

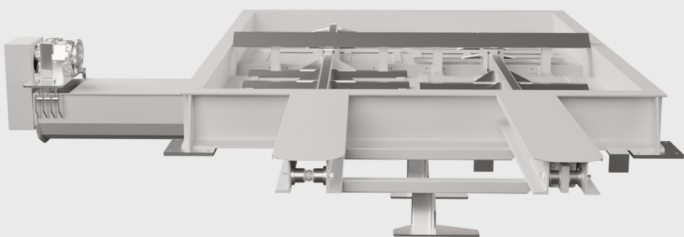

The K.U.S Container Unloading System: is an innovative solution designed for unloading large-scale silos and cyclone bunkers. This versatile system revolutionizes the handling of bulk materials by enabling the conversion of standard shipping containers into efficient storage bunkers. The K.U.S system is ideal for various bulk materials, including sawdust, different types of grain, and other bulk produce, providing a fast, stable, and reliable unloading method without the need for a hopper.

»»» CUSTOM PRODUCTS

Custom Conveyers: our custom industrial conveyor systems are designed to seamlessly integrate with shredders and briquetting presses, providing an efficient and reliable solution for loading materials. Engineered to meet the specific needs of your operations, our conveyors enhance productivity and ease the material handling processes.

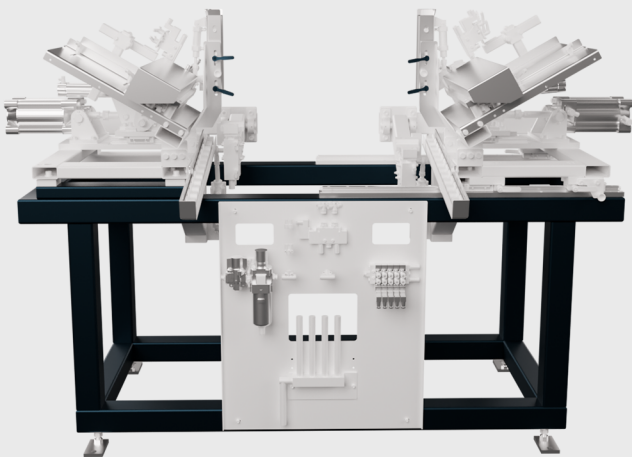

IKEA custom furniture assembly machine: UMP Technika was tasked with building a non-standard furniture assembly table meeting IKEA's highest quality standards. The machine had to glue and press pre-manufactured parts into a single, customer-ready piece, ensuring consistent quality and preserving finishes. It required precise glue dosing and uniform pressing, with no sharp elements to avoid damage.

Rotating elevator: The Rotating Elevator is a crucial tool in woodworking factories, particularly in operations involving material shredding and briquetting. This versatile machine is designed to efficiently manage various tasks, significantly enhancing industrial productivity. It facilitates the smooth transfer and elevation of materials, ensuring continuous workflow and reducing manual handling.

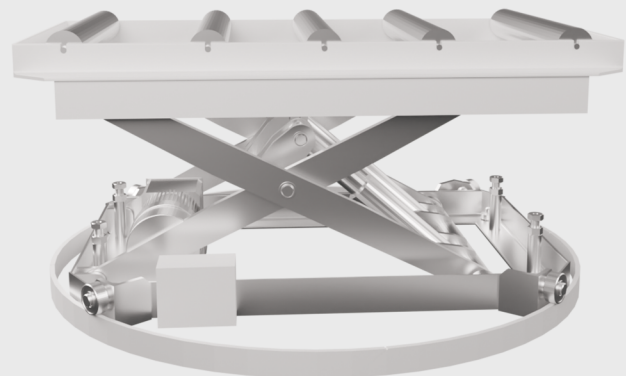

»» **TOGETHER.**
EVERY STEP OF THE WAY ««



technika

UAB "UMP TECHNIKA" | BRIQUETTE.LT

Deltuvos str. 22, LT – 20122 Ukmerge, Lithuania | sales@umpt.lt